



QUANTAX EDS

- Slim-line Technology for SEM and TEM

Excellence in X-ray Analysis for the Electron Microscope



The new generation of QUANTAX EDS features slim-line technology and a wide range of active areas for the XFlash® 6 detector series. Combined with the new enhanced hybrid pulse processor Bruker's EDS detectors once more set the standard in performance and functionality. Generation 6 provides hardware and software technology to deliver the fastest and most reliable results in nano-research.

QUANTAX – your powerful tool for X-ray spectrometry

- Save time – new slim-line technology detectors, large area SDDs, and high performance pulse processing get the job done faster
- Save effort – motorized detector movement and light weight design make detector handling easier
- Gain more precision – best energy resolution provides the highest quality spectra for precise analysis
- Gain more reliability – the world's most comprehensive atomic database ensures most dependable low energy peak identification
- Gain more accuracy – the most sophisticated algorithms for quantification and the unique combinability of standardless and standard-based methods provide highest accuracy results

The 6th Generation of XFlash[®] Detectors



Wide range of detector sizes

- 10, 30, 60 and 100 mm² active area detectors offer ideal solutions for micro- and nanoanalysis



Best energy resolution for light element and low energy analysis

- 121 eV limited edition
- 123 eV ultimate
- 126 eV premium
- 129 eV standard
- All resolutions specified exceeding ISO 15632:2012 requirements



Ultra high throughput for fastest measurements

- New signal processing unit with hybrid technology
- Over 1,500 kcps input count rate
- Over 600 kcps output count rate



Slim-line detector technology for even more counts and lower beam currents

- Shortest detector to sample distances for maximum solid angle in SEM, FIB-SEM, EPMA and TEM
- Best available take-off angle for TEM



Compact design and low weight

- High precision slider with fully integrated motor for precise positioning
- Improved heat sink geometry for stable measurement conditions
- Maximum detector weight of 3.75 kg

XFlash® 6 – the Right Choice for any Application



Every analytical task has different requirements. Bruker offers detectors in different designs and with various active areas to ensure optimal conditions for any individual application. All detectors offer best solid angle per active area.

The XFlash® 6 detector series for SEM and TEM



XFlash® 6 for SEM

Bruker offers a complete range of detectors for SEM, FIB-SEM, and EPMA. XFlash® 6 | 10 and 6 | 30 cover the majority of applications, including high beam current analysis, low voltage (nanoanalysis) and low vacuum operation. XFlash® 6 | 60 and 6 | 100 cover less common areas, like low beam current applications or beam-sensitive samples.

XFlash® 6 | 10 – the best resolution SDD

- 10 mm² detector delivering 121 eV at Mn K α – the best resolution in the market
- Excellent light element and low energy performance

XFlash® 6 | 30 – the highly efficient, versatile SDD

- Mid-size 30 mm² SDD for both nanoanalysis and high count rate spectral imaging
- Perfect companion for high speed EBSD analysis

XFlash® 6 | 60 – the large area SDD for nanoanalysis

- 60 mm² SDD for low beam currents
- Ideal for analysis of nanoparticles, biological samples and the like

XFlash® 6 | 100 – the largest area SDD for low current applications

- 100 mm² active area for special analytical situations
- The ideal choice for low beam current SEMs (cold field emitters) and very sensitive samples



XFlash® 6T | 60

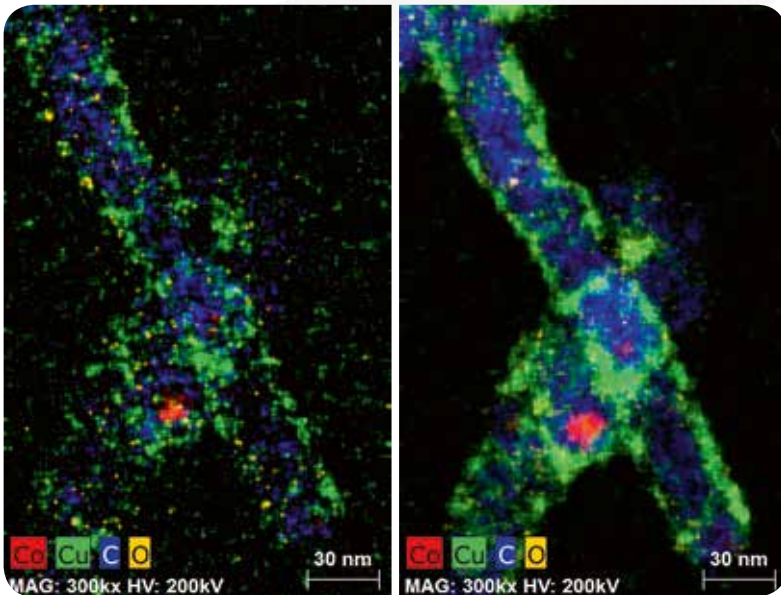

CuO-coated multi wall carbon nanotubes with Co-catalyst particles analyzed with the XFlash® 6T | 30, spot size 1.5 nm, 400 pA beam current. The measurement was performed with two different acquisition times: 3 min (left) and 47 min (right). It can be seen that the 3 min measurement already shows almost all relevant structures, while the longer acquisition time adds detail. Sample courtesy: S. Herrmann, T. Wächtler, Chemnitz University of Technology



XFlash® 6 | 10

XFlash® 6T for TEM

Bruker XFlash® 6T – the large solid angle detectors for TEM and S/TEM offer minimum mechanical and electromagnetic interference. They provide optimum take-off angle and avoid the necessity of sample tilt.

XFlash® 6T | 30 – the first SDD for aberration corrected TEM

- All-rounder for TEM analysis with mid-size 30 mm² chip

XFlash® 6T | 60 – the large solid angle SDD for Å-scale TEM analysis

- 60 mm² active area detector for analysis under low X-ray yield conditions

SDD

Silicon drift detector (SDD) technology for EDS analysis on SEM and TEM was commercially introduced by Bruker. The SDD is a type of energy dispersive solid-state detector. It utilizes a special drift field structure to guide charges produced by absorbed X-rays to an extremely small readout anode. The structure is optimized for each type of SDD – smaller droplet (A) and larger round detector (B) – for efficient charge transportation. Additionally, the XFlash® uses an on-chip amplifier to achieve energy resolutions suitable for EDS element analysis with only moderate cooling, achieved with thermoelectric Peltier coolers. The drift fields, the low capacitance of the readout anode, and the integrated FET ensure the excellent energy resolution and high speed of Bruker's detectors.

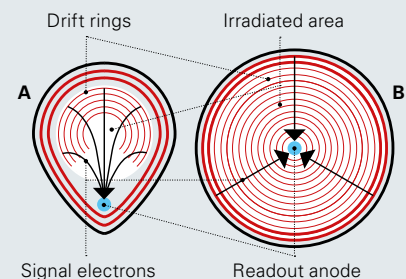

Best Energy Resolution for Challenging Tasks



XFlash® 6 is available with unrivaled 121 eV at Mn K α , providing the excellent energy resolution needed to analyze complex samples – especially in the light element and low energy range below 1 keV.

Excellent energy resolution specifically in the low energy range is essential for ambitious tasks in nanoanalysis. For silicon-based detectors energy resolution typically changes with line energy. The resolution curve of a 121 eV XFlash® 6 detector exactly follows the theoretical limit for the energy resolution. Other SDDs with external field effect transistor (FET) deviate from this curve in the difficult low energy range, due to incomplete charge collection (ICC), which is commonly corrected by software.

Energy resolution – the key to light element performance

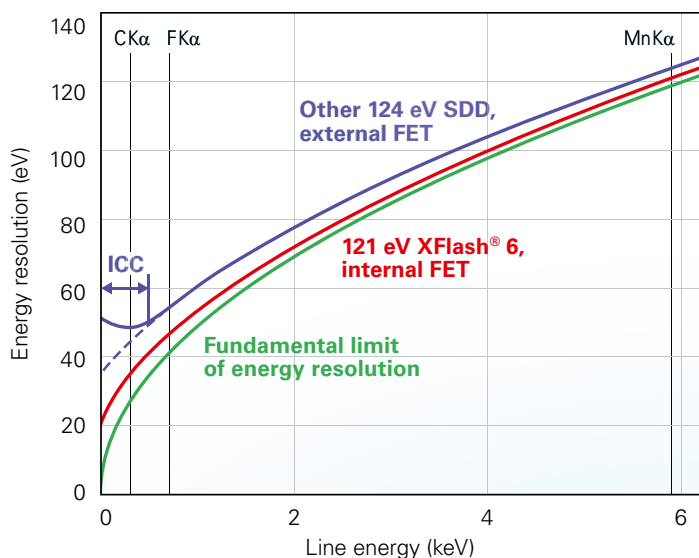

Energy resolution

The power of energy dispersive X-ray detectors to resolve adjacent X-ray lines. The energy resolution is commonly measured on peaks recorded from Mn K α radiation and expressed in terms of the full width at half maximum (FWHM). Energy resolutions for detectors are usually specified in accordance with ISO 15632:2012, where the energy resolution of the K α peaks of manganese (Mn), carbon (C) and fluorine (F) must be given. The smaller the value, the better the energy resolution of the detector.

Energy resolutions of XFlash® 6 detectors

Resolution at Mn K α / eV	Resolution at F K α / eV	Resolution at C K α / eV
121	50	40
123	54	46
126	60	51
129	67	57

The different classes of the XFlash® 6 are characterized by their energy resolution at the Mn K α line. The best class with unrivaled resolution of guaranteed 121 eV is available for the most demanding analytical tasks. This class provides a typical energy resolution of 40 eV for C K α ! Note that a change of only 8 eV at Mn K α results in 17 eV resolution improvement for C K α , more than doubling the resolving power for light elements. All XFlash® 6 resolutions are specified exceeding ISO 15632:2012 requirements.

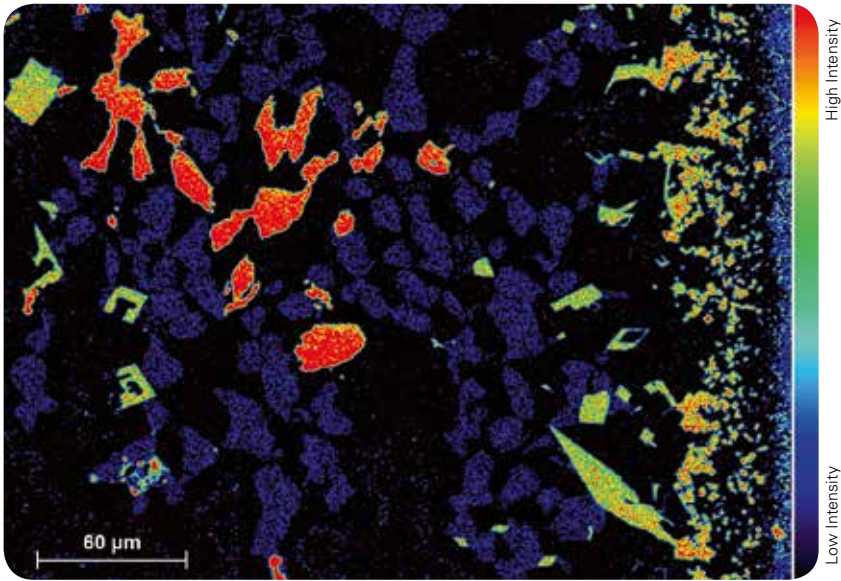

The XFlash® 6 detector with its outstanding energy resolution solves analytical challenges like never before: This boron map of a weld seam shows different borides that are distinguished by their boron content:

The phase with the highest boron content (red) is chromium boride, chromium nickel boride (green) has intermediate boron content, and trinickel boride (Ni_3B , blue) has the lowest boron content.

Comparison of spectra acquired with 129 eV and 121 eV

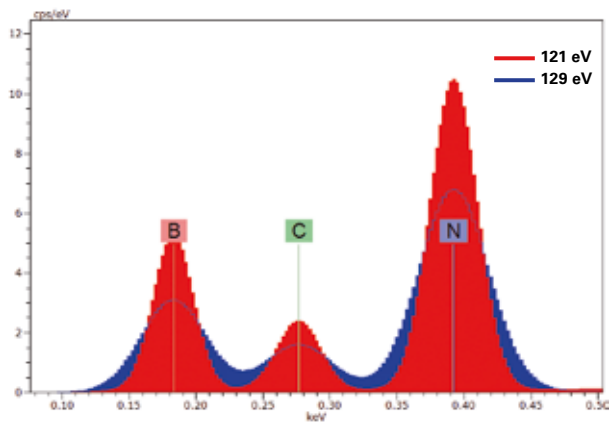

The comparison of two light element spectra obtained with a 129 eV detector (blue) and a 121 eV XFlash® 6 detector (red) clearly shows the advantage of the better resolving detector. The higher and narrower peaks provide a better basis for deconvolution and lower limits of detection.

Low energy range spectra acquired with 121 eV

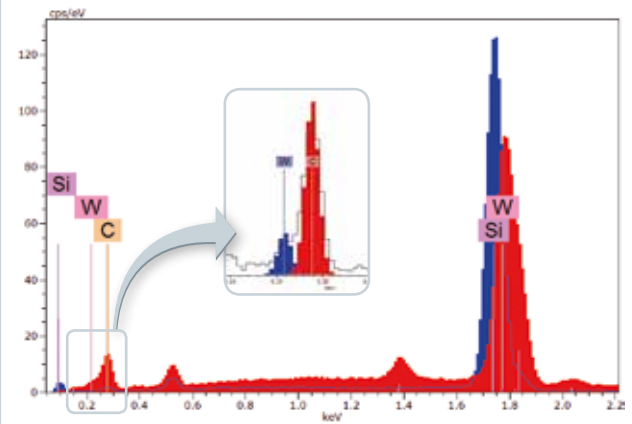

Overlay of the low energy range of a Si and a W spectrum measured with the 121 eV XFlash® detector. Note that the excellent energy resolution of this detector is almost sufficient to separate the Si K and W M lines. Also the Si L line is clearly visible, although the excitation voltage is relatively high at 7 kV. The W N lines can be seen in the low energy slope of the carbon contamination peak. Deconvolution confirms this finding.

Versatile Signal Processing



The new signal processing unit with hybrid technology is a key component of the new QUANTAX. It offers superior pulse processing speed and guarantees reliable results at any count rate. The processor is capable of over 600 kcps output count rate at more than 1,500 kcps input.



The new signal processing unit

Input count rate

The number of X-ray quanta per unit time registered by the detector and converted to pulses arriving at the signal processor.

Output count rate

The rate of signal pulses/counts actually contributing to the spectrum. The output/net count rate is reduced with respect to the input count rate by the value of dead time.

Dead time

The percentage of time the signal processor is occupied with processing signals and therefore unable to accept further pulses. Dead time is inherent to all photon-counting detectors and increases with the pulse load.

Fast and accurate

- Noise free sensor supply
- Precise temperature control
- Ultra high throughput
- Optimum energy resolution
- Automatic operation (user control optional)

Versatile and safe

- Support of up to four detectors in one system
- Separate slider control for each detector
- Hardware and software interlock for safe detector operation

Output vs. input count rate for selected shaping times, specified by the maximum output count rate they deliver

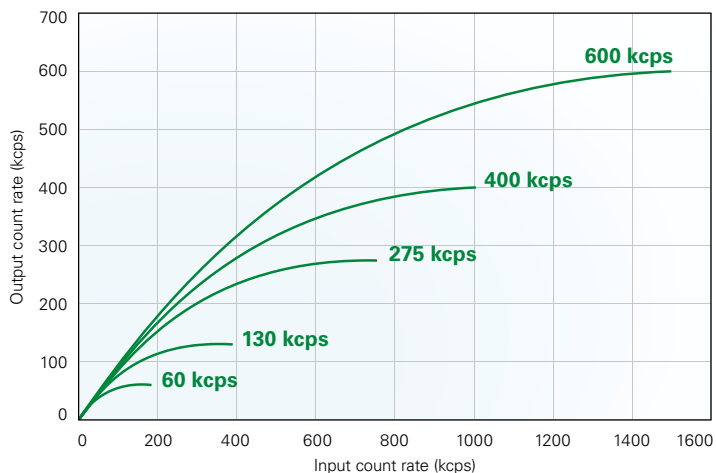

X-ray signal processors typically provide a variety of shaping times to adapt to different signal conditions. QUANTAX frees the user of the task of searching for the right selection by always choosing the optimum shaping time automatically.

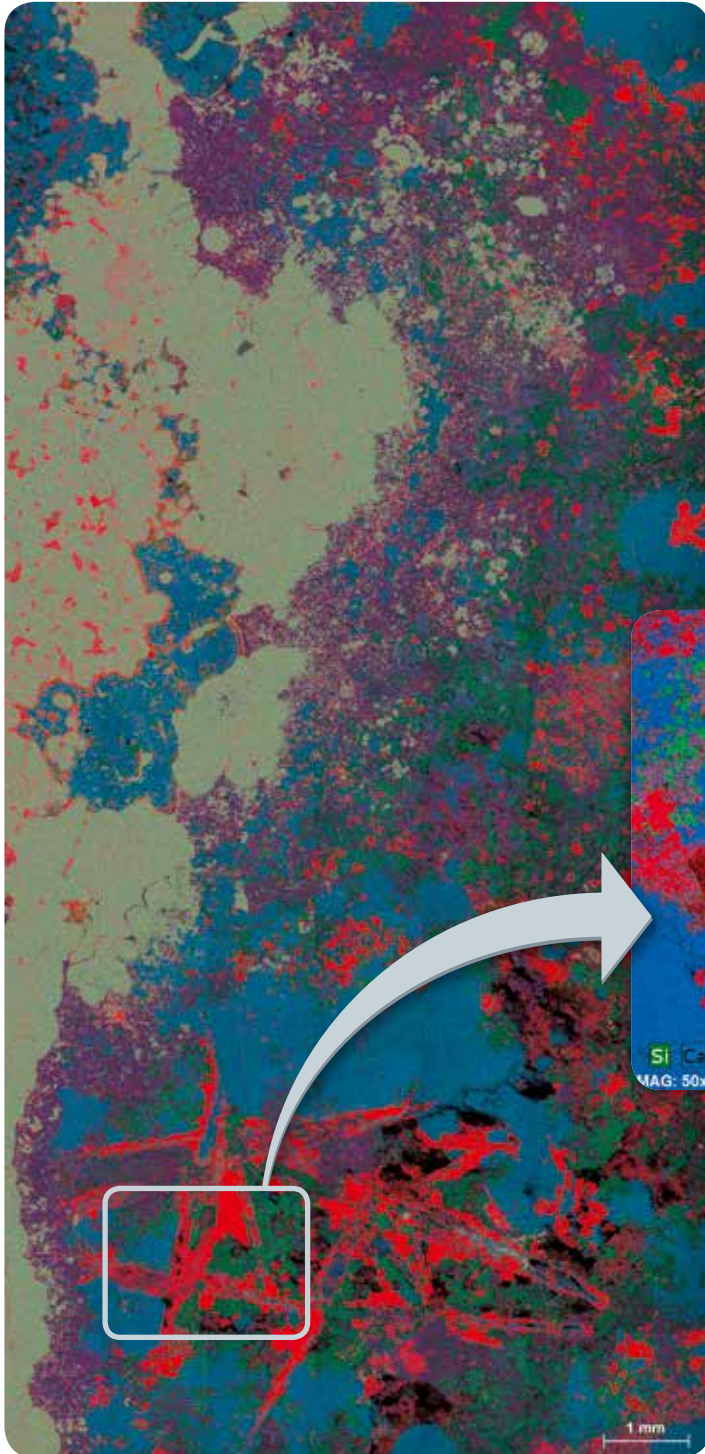

With the 6th generation Bruker's well proven signal processing technology is taken to the next level, providing the perfectly optimized signal analysis setting for any combination of

- Detector size
- Input count rate, and
- Energy resolution requirement

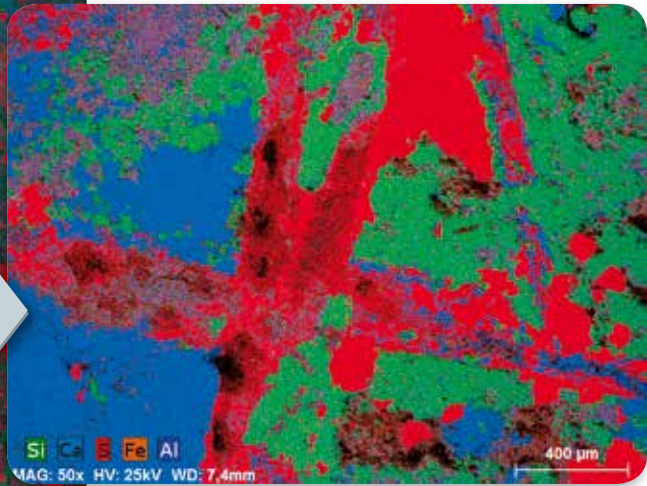

Tiled high count rate map of a pitchblende sample. The complete image was recorded using an XFlash® 6 | 30. The extracted map shows the richness of detail attainable in less than an hour total acquisition time.

High Count Rates for More Productivity



Many applications like mapping or particle analysis require high count rates. With XFlash® 6 their adverse effect on energy resolution is minimal or even nonexistent. XFlash® 6 provides best energy resolution up to 100 kcps count rate and still delivers reasonable resolution at an outstanding input count rate of 1,500 kcps.



Best energy resolution range (BERR) of different detectors

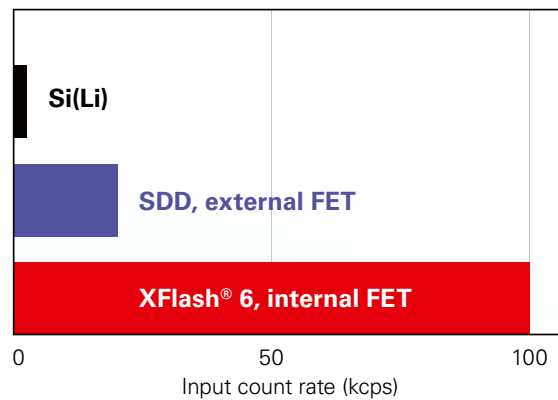

Advanced Si(Li) detectors show fairly good energy resolution at low count rates, but even medium count rates can only be processed at the cost of poorer energy resolution. SDDs generally expand the range of count rates with optimum energy resolution (BERR) while detectors with an integrated amplifier (internal FET) take this to the limit.

XFlash® 6 combines the best available detector technology with an optimized and well adapted hybrid signal processor.

Solid angle

A most important performance figure for a detector since it determines the portion of the total of X-rays emitted by the sample that can be registered. It is defined as the section of an imaginary sphere around the sample that is covered by the active area of the detector when it is in working position. Solid angle is measured in steradian (sr) and roughly proportional to active area divided by the square of the sample-detector distance. This stresses the importance of the detector to sample distance: A detector with small active area close to the sample can achieve the same or a better solid angle than a detector with large active area but longer distance to the sample.

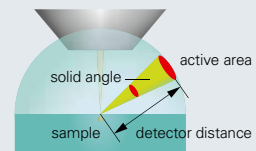

Take-off angle (TOA)

The mean angle at which the part of the X-rays that is recorded by the X-ray detector leaves the sample surface. A higher TOA reduces self-absorption and sensitivity to surface contamination or coatings.

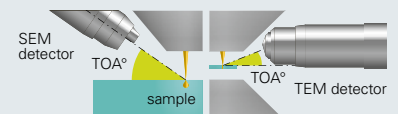

Slim-line, Compact and Flexible



All XFlash® 6 detectors feature slim-line technology and compact, light-weight design. The advantages are optimum acquisition conditions, including large solid angle and high take-off angle, as well as low load on the column, highly efficient cooling and convenient use.

Slim-line technology means ultra-thin detector fingers, providing

- Maximized solid angle
- Clearance of other detectors
- Optimized take-off angle



Advantages of compact and light-weight design

- Minimal interference on the electron microscope
- Reduced weight of less than 3.75 kg
- Reduced overall height
- New high precision motorized slider
- Exact repositioning of the detector
- New larger surface area heat sink
- Optionally available with welded bellows (standard for XFlash® 6T)

Working distance

A SEM parameter defined as the distance between the sample and the lowest part of the pole piece. It is normally chosen to optimize the electron optical properties but with EDS, it also has to accommodate the fixed detector position. VZ allows a new degree of freedom.

Maximum measurement flexibility through VZ (variable Z)-Adapter

- Tilt and move the detector into the optimum working distance
- Maximized solid angle and count rate
- Optimized in-situ adjustment of combined EDS and EBSD measurements

Optimized detector to sample distance through slim-line technology

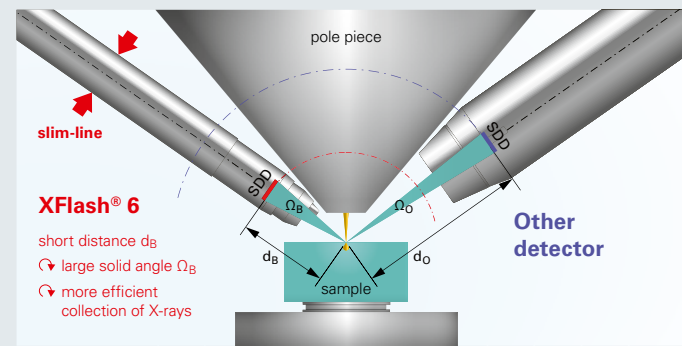

Optimized measurement geometry through VZ-Adapter

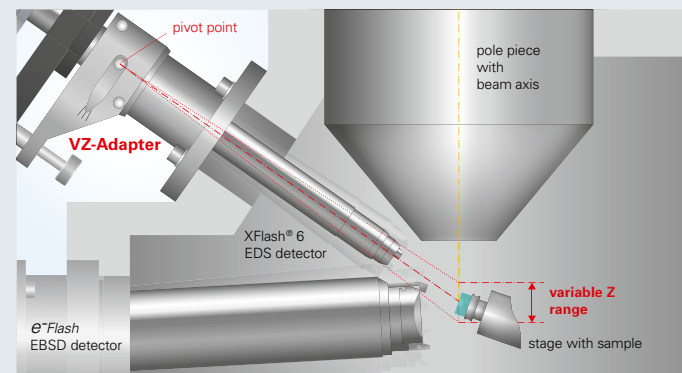

ESPRIT – the Ideal Analytical Software Suite for SEM and TEM



ESPRIT user interface

- 1 Hardware control
- 2 Project explorer
- 3 Acquisition and evaluation
- 4 Function-specific section
- 5 Main menu



Real-time spectrometry

- Instant spectrum visibility
- Live quantification



HyperMap

- The database contains a spectrum for each pixel
- Enables on- and offline processing
- Live background removal and peak deconvolution



Light element / low energy analysis

- Most comprehensive database containing K, L, M and N element lines for accurate identification
- TQuant – optimized standardless low energy range quantification



Automation of routines

- Automate virtually any measurement and analysis procedure
- Optimization of instrument usage
- Unattended operation during the day, at night or over the weekend



Hybrid quantification

- Unique combination of standardless and standard-based quantification
- Customizable for most accurate quantitative results

Real-Time Spectrometry – See Composition Changes Immediately



Taking advantage of the new XFlash® 6 detectors' speed, the real-time spectrometry function offers instant information on local sample characteristics.

Every analysis begins with the selection of the point or area of interest. The QUANTAX real-time spectrometry capabilities facilitate this process. In the preview mode the spectrum is updated at intervals down to 100 milliseconds. The user can easily recognize changes in the spectrum as the measurement spot is moved across the sample.

Live quantification

While the acquisition is running, ESPRIT can perform live quantification and update results as statistics improve. Everything is done automatically, but if desired, intermediate results can be reviewed or quantification can be done interactively.

Real-time spectrometry and live quantification in ESPRIT

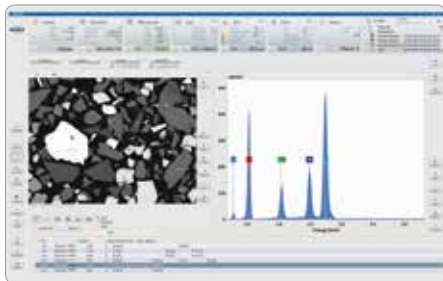

Viewing the spectrum at different spots in real-time

Performing quantification interactively



Results review

Spectrometry is supported by ...

- Automatic or user controlled acquisition
- Automatic or manual element identification
- Accurate background fitting
- Peak deconvolution using either peak fitting or probability theory based approaches
- State-of-the-art quantification routines

P/B-ZAF

Fundamental parameter quantitative analysis, based on evaluating characteristic X-rays (peaks) as well as bremsstrahlung background. The local peak to background (P/B) ratios are input to a modified ZAF matrix correction. The P/B-ZAF analysis is self-calibrating. Because characteristic X-rays and bremsstrahlung undergo the same absorption, P/B-ZAF is relatively insensitive to local sample tilt and the surface condition of the specimen.

Matrix correction

Algorithm that relates the recorded spectrum to the primary rate of X-ray generation. Matrix correction takes into account atomic number effects (Z), absorption effects (A) and secondary fluorescence effects (F).

Unsurpassed Light Element and Low Energy Analysis



Producing reliable analytical results is a challenge, especially at low X-ray energies. Building on the excellent low energy performance of the XFlash® detectors, the ESPRIT software contains several features supporting nanoanalysis in the light element / low energy range.

Correct element identification based on the most comprehensive atomic database

Bruker continuously updates the ESPRIT atomic database, adding further lines and improving accuracy of line energies and intensities. The result is the most comprehensive atomic database containing all confirmed K, L, M and N lines of all elements that can be analyzed with EDS, enabling reliable element identification even at low energies.

TQuant for accurate standardless results

The TQuant standardless low energy quantification procedure provides excellent results. It is now possible to perform reliable quantitative EDS analysis not only in the light element / low energy range but also with spatial resolution at the nanometer scale. Low beam energies in the electron microscope, which produce only small excitation volumes, can now be safely used for quantitative analysis.

Upper image: A spectrum of a Pt-containing sample acquired at 3 kV. The carbon peak is broadened and seems unusually high for a contamination layer. It can be assumed that the platinum N lines at 251 eV play a role. Lower image: Deconvolution results prove that the carbon peak is "broadened" due to the overlap with the Pt N peak.

The importance of N-lines

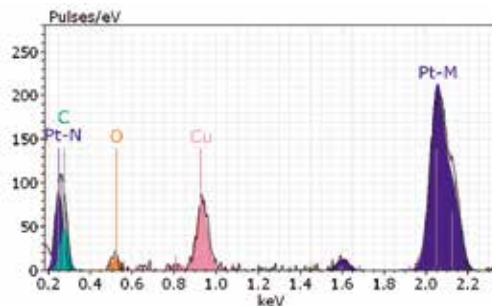
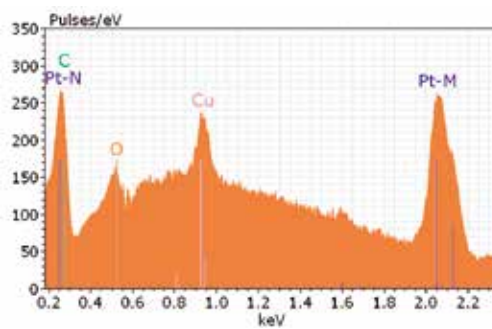

Quantitative light element analysis results

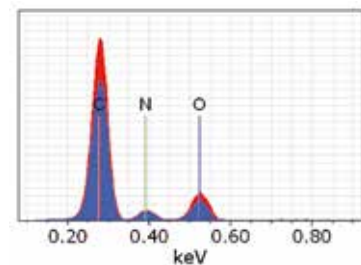

	C	N	O
3 kV	73.1	10.6	16.3
5 kV	70.2	11.6	18.2
Theory	71.1	13.3	15.5

Spectra: Nylon spectra acquired at 3 kV (blue) and 5 kV (red). Table: Analysis results in atomic percent for carbon (C), nitrogen (N) and oxygen (O) in comparison to theoretical concentrations (hydrogen (H) content neglected).

HyperMap – Measure First, Analyze Later

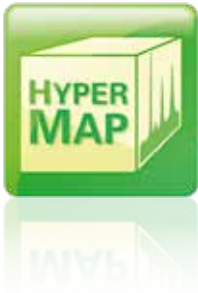

ESPRIT HyperMap is one of the most versatile tools for EDS analysis. Select an area of interest, set up the acquisition, collect a map – even without any prior knowledge of sample composition – and analyze it offline.

HyperMap allows acquiring an advanced type of element map, in which a complete spectrum is stored for every pixel in the map. The collected database, or spectrum image, permits further processing and analysis of the data at any time during or after the measurement.

Processing tools include extracting, quantifying and comparing EDS spectra of selected regions in the map, calculating a Maximum Pixel Spectrum, obtaining line scans, displaying a map for any element, as well as automatic phase analysis.

HyperMap of a mineralogical sample

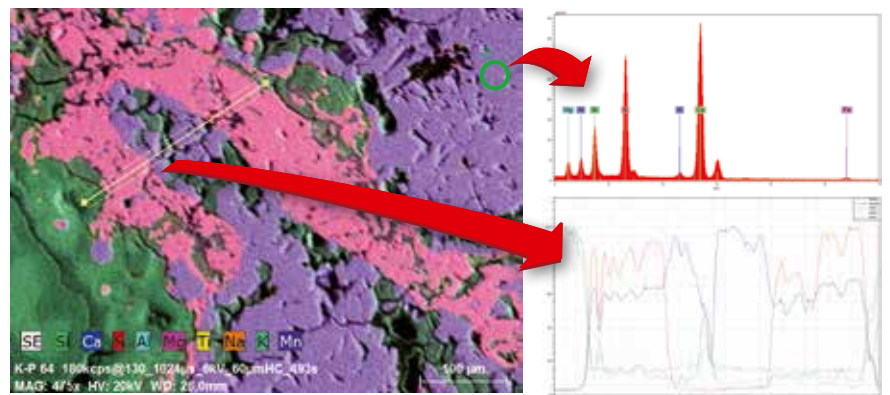

A sum spectrum was extracted from a circular region (green outline) in the upper right corner of the HyperMap. A line scan (yellow line) was extracted and broadened, visible by the narrow yellow outlines, for improvement of statistics.

The HyperMap data cube contains a spectrum for each pixel.

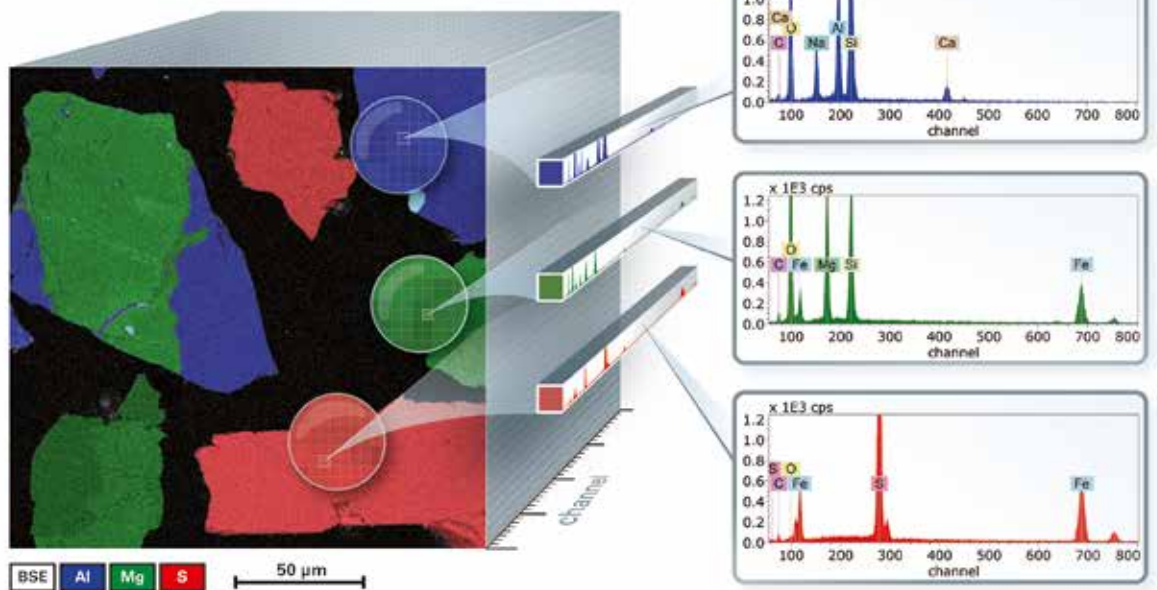

Comparison of sum spectrum and Maximum Pixel Spectrum

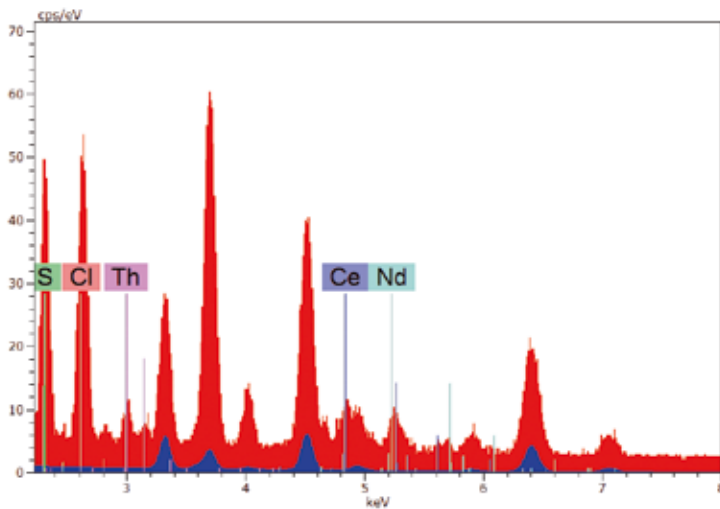

Comparison of a sum spectrum (blue) and a Maximum Pixel Spectrum (red) of a granite sample. The Maximum Pixel Spectrum shows peaks in the mid energy range that are not visible at all in the sum spectrum, as they are averaged out. The few small monazite particles in the granite, that contain rare earth elements (Ce, Nd, Th), can only be detected using the Maximum Pixel Spectrum.

Further data acquisition and analysis options

- Single point measurement
- Multi-point measurement
- Qualitative and quantitative line scan
- Qualitative and quantitative map
- ColorScan

ESPRIT offers a range of advanced tools for data processing and reporting

- Image acquisition and editing
- Feature analysis, including chemical classification
- Special applications packages: Steel inclusion analysis, gunshot residue analysis (GSR)
- Report generation, automated or interactive, including MS Word® export

Maximum Pixel Spectrum – the perfect tool for trace analysis

The highest count rate recorded in each energy channel, for each pixel in the map, is displayed in a synthesized spectrum. If a certain element has a high concentration, the corresponding peak becomes visible in the Maximum Pixel Spectrum, even if this element is present in only a single pixel of the map.

Phase analysis using Autophase

ESPRIT's Autophase function determines the present chemical phases using an automated principle components analysis (PCA) algorithm. The conditions for analysis are either set by different thresholds (automatically or manually) or by defining objects in a map.

ColorScan

During scanning the image is displayed in color by combining X-ray and electron information in real-time. ColorScan provides instant qualitative information on sample composition, homogeneity and even on different phases.

Powerful Automation



Automation of routine analyses is easily set up and performed with ESPRIT. Return to the lab after a night's unattended measurement run, to find all results on disk or compiled into a report.

Full analysis automation with ESPRIT Jobs

Virtually any analytical function can be automated using Jobs (including feature analysis):

- Unattended multiple sample analysis
- Analysis of multiple regions of interest on a single sample

- Utilizing the StageControl function allows defining an area or storing multiple stage locations
- Measurement results are automatically stored
- Optional automatic report generation

ESPRIT Jobs

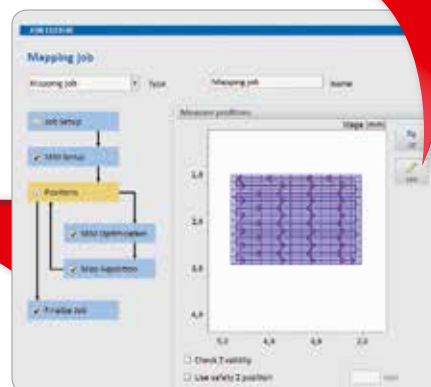
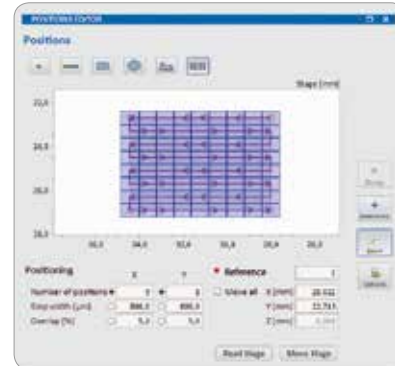
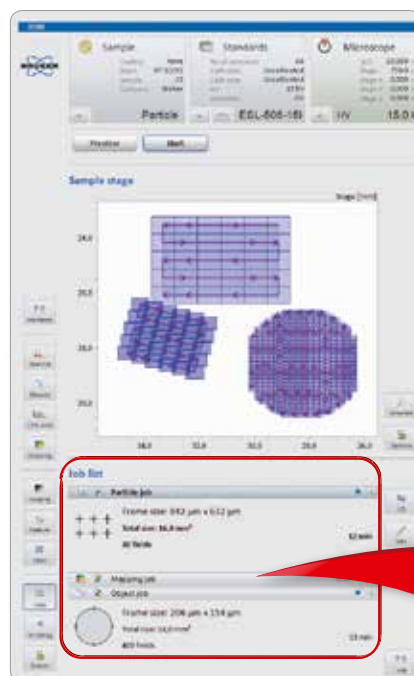

Easy setup of automated analyses

Specifications



Detector configurations for QUANTAX systems

Available detectors for SEM	XFlash® 6 10 XFlash® 6 30 XFlash® 6 60 XFlash® 6 100	Available detectors for TEM	XFlash® 6T 30 XFlash® 6T 60
------------------------------------	---	------------------------------------	------------------------------------

ESPRIT software

Module	Description	Module	Description
Spectrum	Spectra acquisition, element identification	Map	Ultra high speed digital X-ray mapping
Quant	Automatic standardless quantification	QMap	Quantitative mapping
EQuant	Extended spectrum analysis options	HyperMap	Mapping with hyper spectral database
UQuant	User defined quantification strategies	MaxSpec	Element trace determination for HyperMap
TQuant	Optimized low energy quantification	AutoPhase	Automatic phase analysis
HSQuant	Combined $\Phi(\rho z)$ and standardless analysis	Feature	Feature analysis (optionally automatic)
CLQuant	Cliff-Lorimer quantification	DriftCorr	Correction of beam drift
SpecMatch	Spectrum matching, search similar spectra	StageControl	Motorized stage control
SEMLink	Data communication with microscope	Jobs	Automatic task processing
Scan	Image acquisition	Project	Data management and filing system
ColorScan	Acquisition of X-ray induced color images	TChart	Histograms, binary and ternary charts
Vision	Digital image processing and enhancement	Report	Result presentation and report generation
ImageStitch	Automatic stitching of overlapping images	User	Multi-user operation and administration
MultiPoint	Automatic multi-point and object analysis	LAN	Client/server architecture
Line	Spectrum data based line scan	Support	Application support and remote diagnosis
QLine	Quantitative line scan	EMSA	Spectra import and export in EMSA format

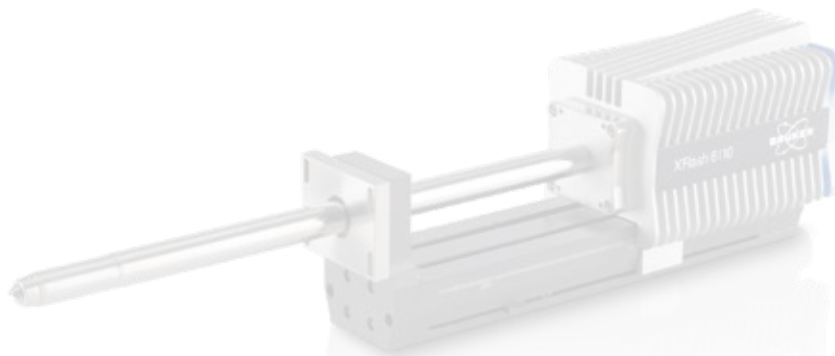

For further information please scan the QR code or visit www.bruker.com/quantax

● **Bruker Nano GmbH**
 Berlin · Germany
 Phone +49 (30) 670990-0
 Fax +49 (30) 670990-30
info.bna@bruker.com

www.bruker.com