



Confocal Microscope AX/AX R

# AX AX R

Confocal Microscope



Shedding New Light On **MICROSCOPY**



## Improving on Perfection

Confocal microscopes have been commercially available now for over 25 years. How can newer iterations of a fundamentally simple instrument continue to innovate? What changes can redefine how a confocal is used, and what data can be collected? Introducing the Nikon AX/AX R Confocal Microscope System, our 10th generation point scanning confocal, giving you more of everything: Leveraging Artificial Intelligence (AI), expanding the number of colors, improving pixel density, sensitivity and speed.

These are significant additions in terms of expanding the range of experiments possible with a point scanning confocal, while increasing the usability and functionality of the instrument, all in a modular and upgradable platform.

**Nikon AX is the new standard in confocal imaging**

Maximum intensity projection of Z stack images of cleared mouse brain acquired with a 60x 1.27 NA water immersion objective using 2048 x 2048 pixel resonant scanning

# See More of the Specimen

With the largest field-of-view on both inverted and upright microscope stands available (25 mm diagonal), more specimens fit in one FOV with more objective lens choices than ever before. Coupled with scanning sizes up to 8192 x 8192 pixels, sampling beyond the optical diffraction limit is possible even at low magnifications with the AX/AX R. Using lower magnifications with longer working distances and high numerical apertures enables more flexible specimen preparations to be used, while the large FOV allows simultaneous high resolution in one image. Collect more data in every image, and at faster rates.

The AX/AX R has a 25 mm diagonal FOV, much larger than other confocal instruments.

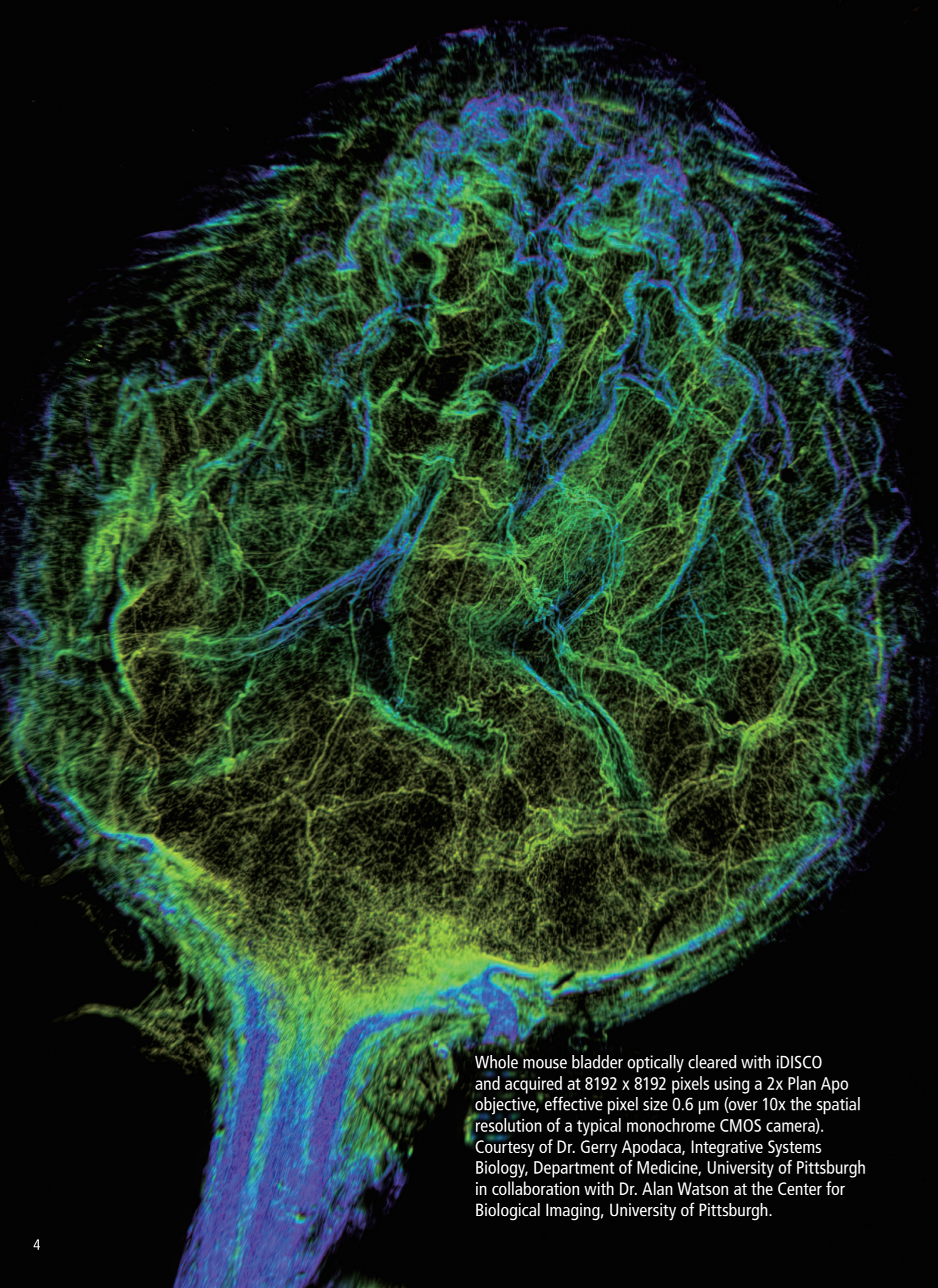

Whole mouse bladder optically cleared with iDISCO and acquired at 8192 x 8192 pixels using a 2x Plan Apo objective, effective pixel size 0.6  $\mu\text{m}$  (over 10x the spatial resolution of a typical monochrome CMOS camera). Courtesy of Dr. Gerry Apodaca, Integrative Systems Biology, Department of Medicine, University of Pittsburgh in collaboration with Dr. Alan Watson at the Center for Biological Imaging, University of Pittsburgh.

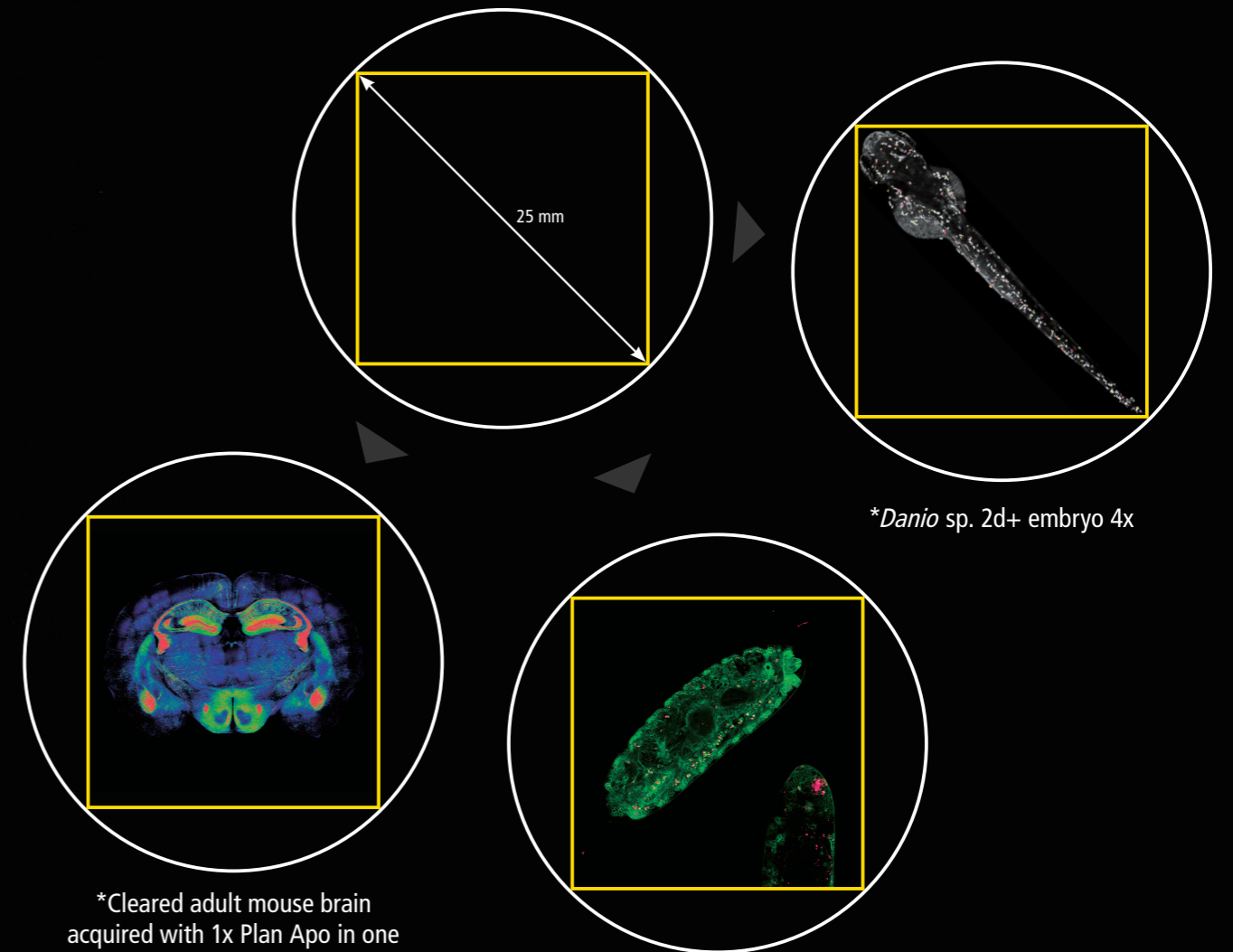

\**Danio* sp. 2d+ embryo 4x

\*Cleared adult mouse brain acquired with 1x Plan Apo in one acquisition of 1 FOV

\**Drosophila* sp. embryo development easily fits within the FOV using a high NA 25x SIL 1.1 NA objective

\*It would not be possible to capture this sample in one FOV or at this resolution with other commercial confocal systems

# Observe with Minimal Disturbance...

Laser scanning confocal imaging is principally challenging on specimen viability, as it applies focused laser illumination point by point on a sample.

The AX R's high speed resonant scanning, which decreases the illumination time by more than 20x typical confocal scanning times, greatly reduces biases caused by merely acquiring images.

Reducing the acquisition time also allows for extremely high-speed imaging (up to 720 fps at 2048 x 16 pixels).

The result: longer imaging and/or more frequent imaging at high speed of living samples which allows capture of dynamic events, but also allows longer time-lapse imaging or significantly faster collection times on fixed specimens.

Time-lapse Z series maximum intensity projection images of a developing *Drosophila* embryo expressing PLC-PH::GFP (PIP2) acquired every 10 minutes for 12 hours at 2K x 1K pixels using a 25x silicone immersion objective. Courtesy of Yang Hong Laboratory, Department of Cell Biology, University of Pittsburgh in collaboration with the Center for Biological Imaging.

# ...and Acquire more Rapidly...

Confocal imaging, notoriously slow because of its point-scanning requirement for high quality 3-dimensional imaging at high resolution, is greatly changed by fast imaging with the AX R's resonant scanning capabilities.

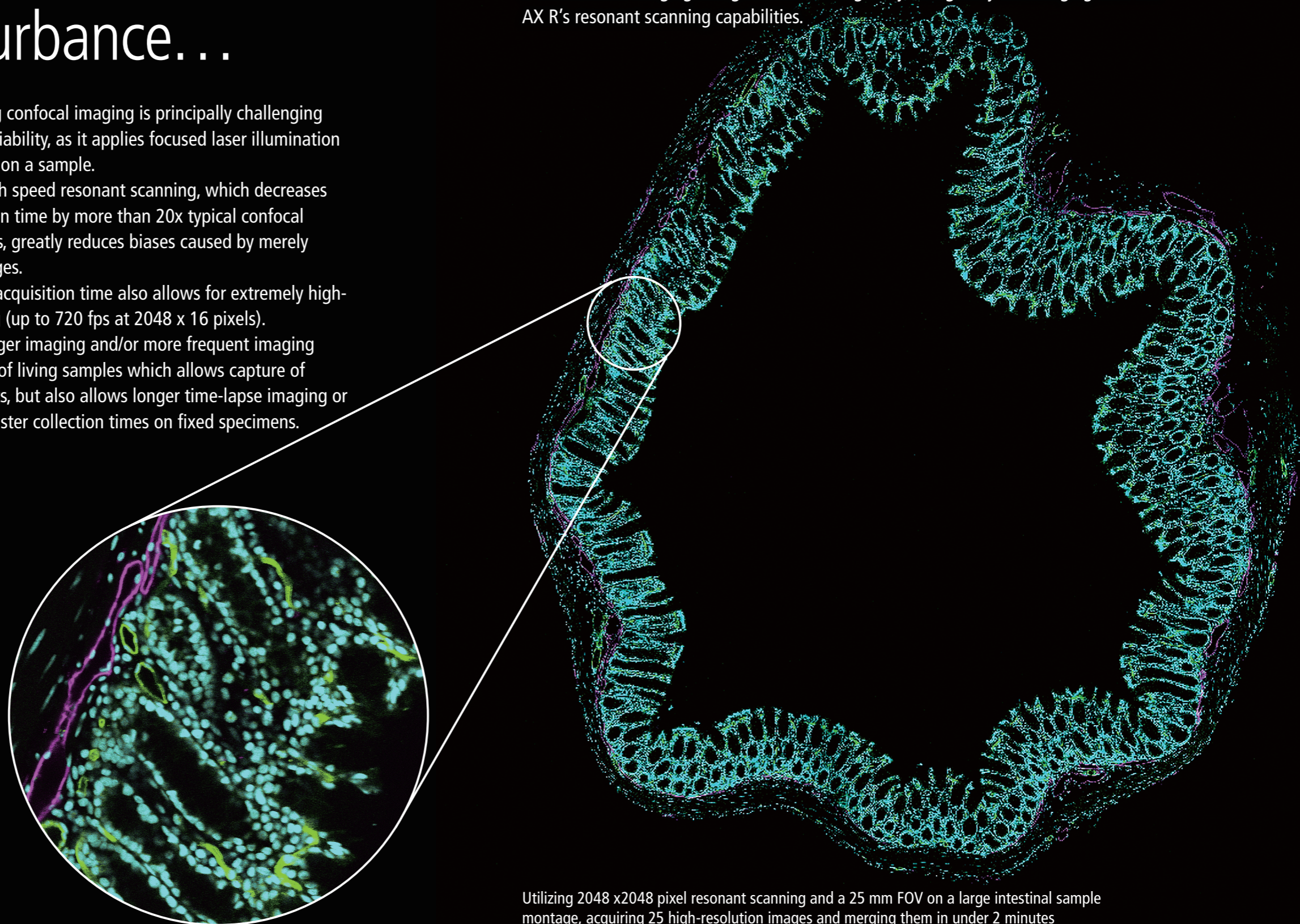

Utilizing 2048 x 2048 pixel resonant scanning and a 25 mm FOV on a large intestinal sample montage, acquiring 25 high-resolution images and merging them in under 2 minutes

# ...and with Ultrafine Detail

With a full 25 mm FOV, up to 8192 x 8192 pixels, and the capability for supravideo frame rates, the AX/AX R allows for spectacular imaging with high resolution, at both low and high magnifications. The entire range of a whole organism or system biology down to intracellular imaging is achievable on one instrument.

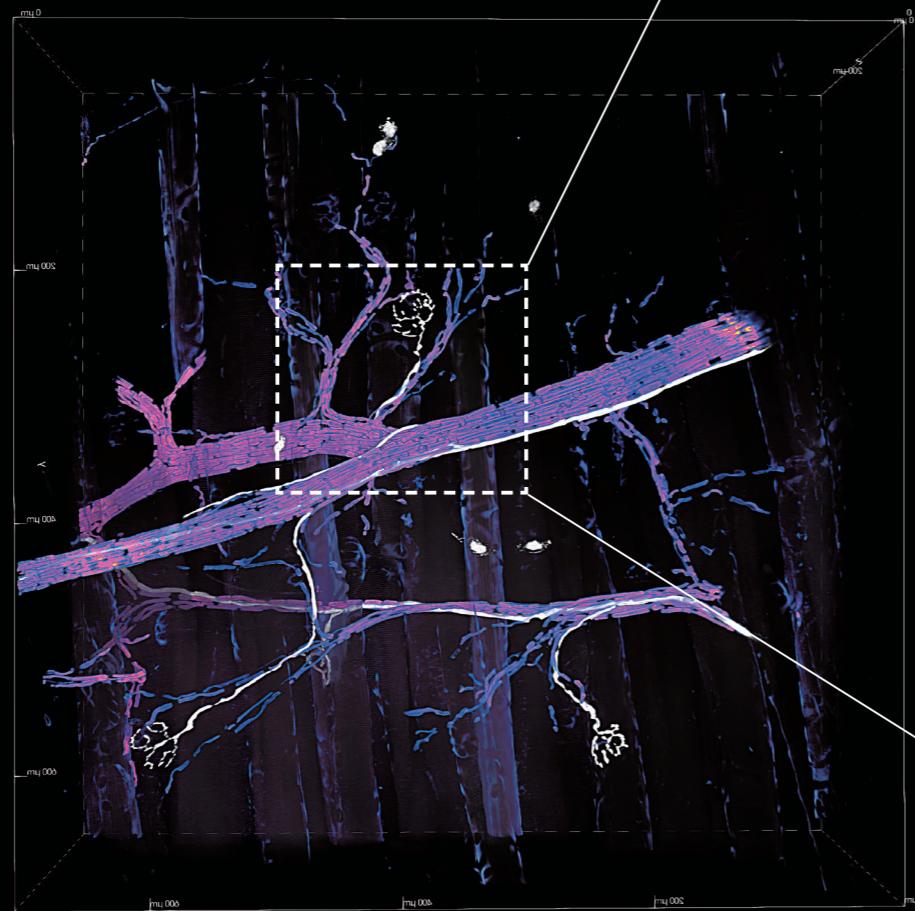
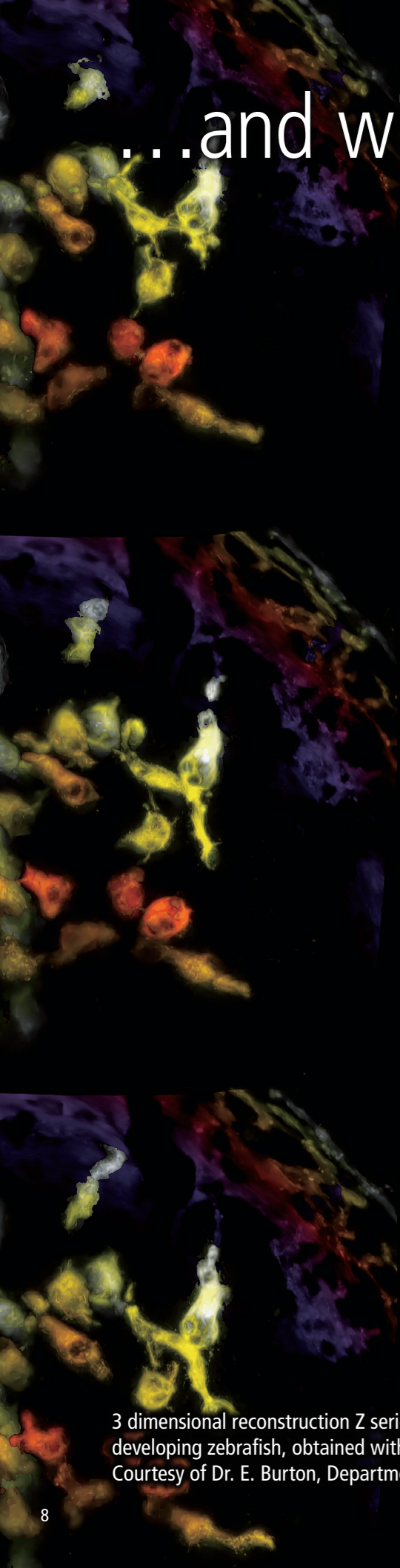

3 dimensional reconstruction Z series (color coded by Z depth) of microglial movement in developing zebrafish, obtained with high speed resonant imaging and piezo Z stepping. Courtesy of Dr. E. Burton, Department of Neurology, University of Pittsburgh.

Mouse muscle acquired with a 25x SIL immersion objective using 2048 x 2048 pixel resonant scanning

# Detectors In Tune with Labels

The AX/AX R's all new DUX-VB detector custom-tunes emission bandwidths to a library of labels and probes, and provides the freedom to fine-tune emission bands to minimize unwanted fluorescence. Simply select the number of labels in your specimen and their catalog names. Alternatively, you can define the desired emission ranges, or even simply the emission color: the AX/AX R and NIS-Elements software does the rest, including optimizing the dichroic mirror and laser excitation choices best suited for imaging. Or, acquire hyperspectral images in up to 66 emission channels for unmixing.

Optionally, the AX/AX R's base DUX-ST detector allows up to 12 discreet bandpasses of emission, upgradable to 24.

And all detector systems can be customized with high sensitivity and low noise GaAsP or Multi-alkali PMT detectors to provide the best detector for sensitivity and wavelength response requirements as well as budgets.

Maximum intensity projection of Z stack images of marmoset brain acquired with a 60x 1.27 NA water immersion objective using 2048 x 2048 pixel resonant scanning and a DUX-VB detector with user-defined emission bands.

# Superior Optics for Confocal imaging

Controlling the manufacturing and implementation of optics from raw materials all the way to complete microscope systems brings unparalleled optical quality and performance. Complimentary optical design means the confocal system, microscope, and objectives all are optimized and matched for superior quality and resolution. Nikon's CFI60 and 75 infinity corrected optical system has numerous options for magnifications, working distances, and immersion mediums, paired for use with an extremely wide variety of samples and specimen preparations.



**CFI Plan Apochromat Lambda S 25XC Sil/40XC Sil**

Using silicon oil as the immersion liquid when imaging objects having a refractive index of around 1.4 enables this lens to acquire high quality images with reduced spherical aberration, even with thick samples.



**CFI Apochromat LWD Lambda S 20XC WI/40X WI**

This objective corrects chromatic aberrations in a wide wavelength range from visible to near-IR light. With its high numerical aperture, as well as long working distance, it is a powerful tool for imaging thick living specimens.



**CFI Plan Apochromat Lambda S 10X**

This objective provides superb aberration correction up to the periphery of its large 25 mm field of view, enabling sharp image acquisition of entire samples with digital cameras that have large image sensors. It also corrects chromatic aberration over a wide wavelength range.



**CFI Plan Apochromat VC 60XC WI**

A water immersion objective that ensures clear image acquisition even within the deep areas of samples. It corrects chromatic aberrations in the shorter wavelength range and is suitable for multicolor confocal imaging.

Maximum intensity projection of Z stack images, color-coded by depth, of vascular development in embryonic zebrafish acquired with a 10X 0.45 NA Plan Apo Lambda S objective using 1024x2048 pixel resonant scanning. Courtesy of Erika Driekorn and Dr. Beth Roman, Department of Human Genetics, University of Pittsburgh Graduate School of Public Health.



# Comprehensive Imaging Software

NIS-Elements Imaging Software allows integrated control of microscopes and peripheral devices, as well as confocal systems. In addition to various functions for confocal imaging, it has a wide range of AI tools that support streamlining of image analysis and optional modules that enable customization of analysis and experiment workflows.



## ER (Extended Resolution)

NIS-Elements ER can be used to improve confocal spatial resolution up to 120 nm (lateral)/300 nm (axial) using GPU-processing with automatic parameter settings and user-defined options.

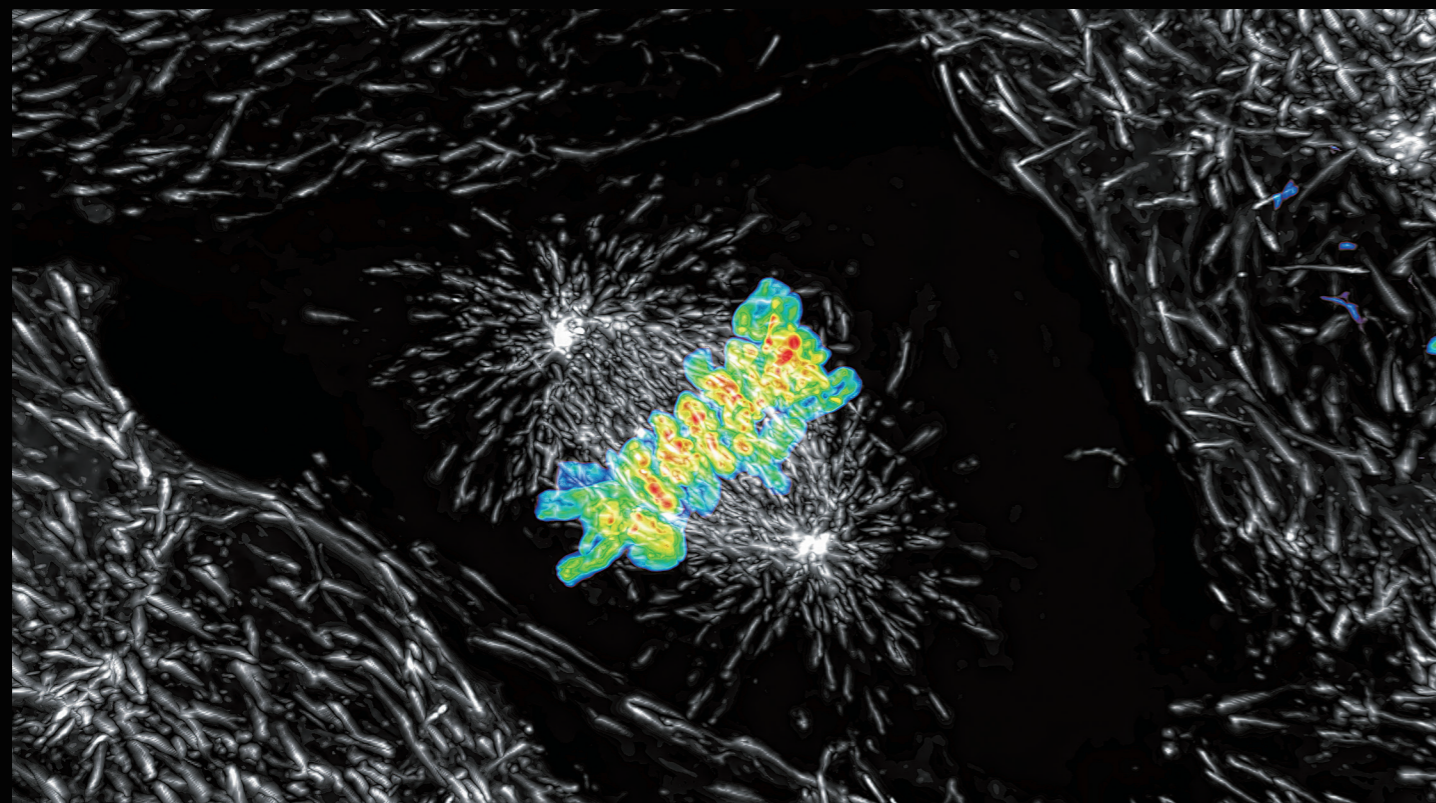

Maximum intensity projection of Z stack images of a live sample to which ER has been applied, acquired with a 60x 1.4NA Plan Apo Lambda oil immersion objective using 2048x1024 AX R resonant scanning at 15 fps.



## Customized Definition of Experiments

NIS-Elements has built-in multidimensional (multi-XYZ,T, multichannel) experiment capabilities. Adding the optional JOBS module allows even more customization such as setting up non-orthogonal experiments with multiple paths and dimensions.

Oftentimes, experiments require customization to streamline acquisition and capture all necessary data points.

Analysis of data can be done even in real-time during the experiment, and the direction of the experiment can even be changed based on the results of the analysis.

Users have ultimate flexibility in designing experiments that maximize their data output needs.

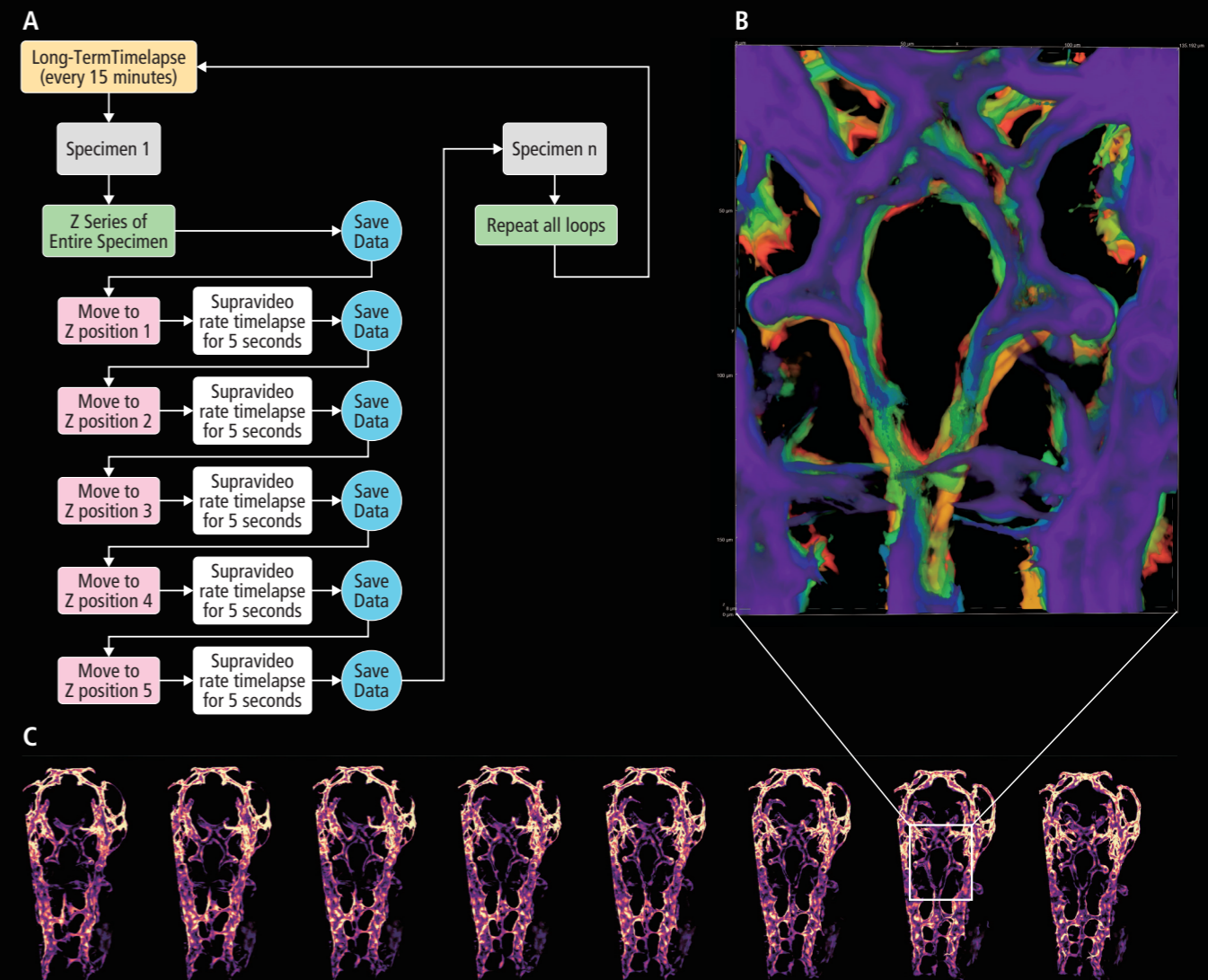

Time lapse images of *Danio* sp. vascular development acquired with a 25x SIL immersion objective using 1024 x 2048 AX R resonant scanning.

(A) JOBS experiment protocol shown above.

(B) Inset showing vascular development with overlay color representing time, where each color represents a different time point.

(C) Maximum intensity projections of entire FOV of Z series at points in time during the progress of the experiment.

Courtesy of Erika Driekorn and Dr. Beth Roman, Department of Human Genetics, University of Pittsburgh Graduate School of Public Health.



# AI Software Innovations Designed to Assist

From acquisition to analysis, Nikon's NIS-Elements software is a pioneering leader in the implementation of convolutional neural network (CNN) based deep learning for microscopy. Several AI tools are available, many targeted specifically for assisting users in acquiring, processing, and analyzing confocal data. These tools aid users in achieving adequate signal-to-noise ratio (SNR) images for image processing and analysis, and more tools for both segmentation and image enhancement or modality transformation.

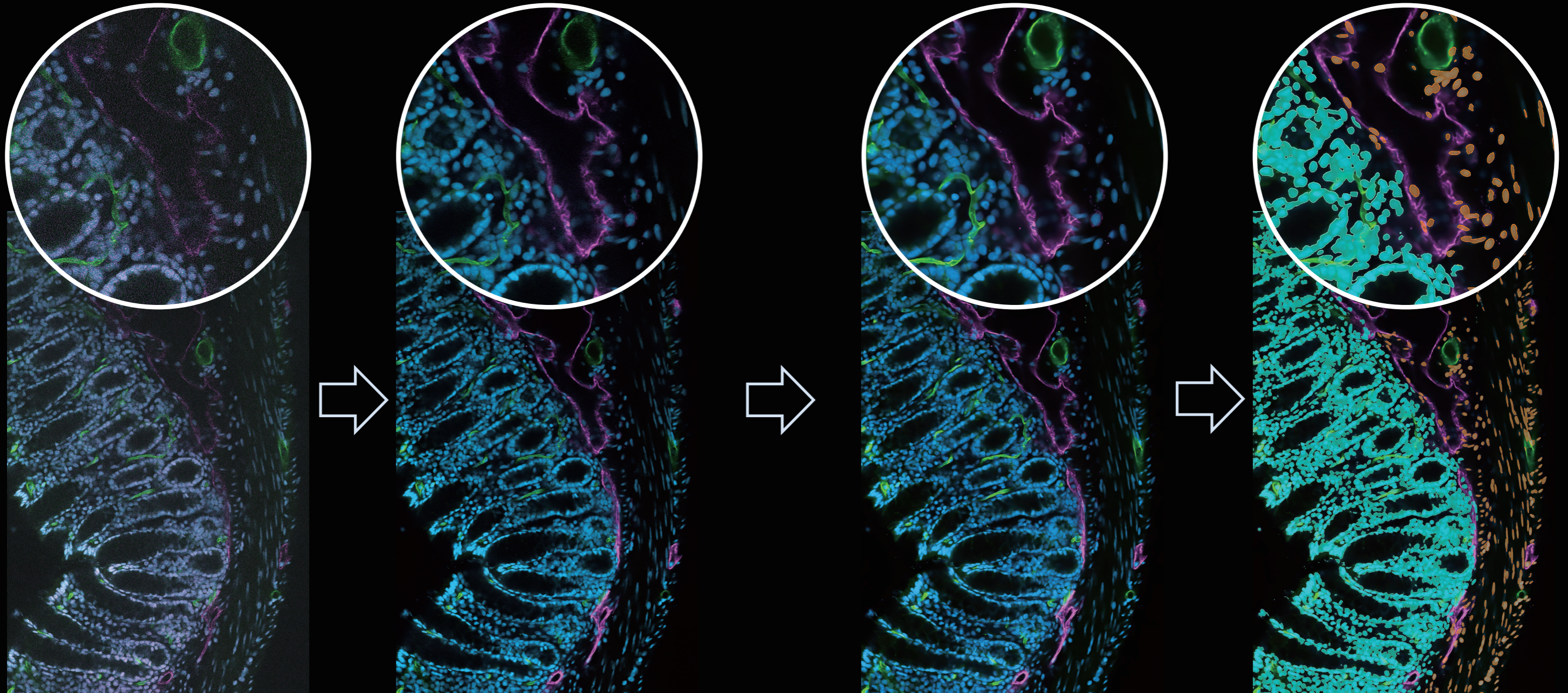

## Starting Point

Confocal imaging has multiple variables that must be fine-tuned for the best image quality, a statistically valid signal-to-noise ratio, and long-term sample stability. NIS-Elements AI tools are designed to assist in achieving these targets.

## Autosignal.ai

New for AX/AX R: Autosignal.ai can suggest the best illumination and detection settings automatically, instead of users manually attempting to find the best settings by trial and error, or while scanning live and exposing the sample unnecessarily.

## Denoise.ai

Shot noise is the main noise source in confocal imaging. Denoise.ai can remove the shot noise component from confocal images, improving the image quality and assisting in downstream segmentation.

## Segment.ai

A toolbox of AI functions assist users in easy segmentation of images; after training the AI, segmentation that would take hours by traditional methods (such as samples with uniform intensity, making traditional thresholding of different morphologies nearly impossible) can be done in seconds.



# Optional Components



## Water Immersion Dispenser

A software-controlled, automatic water dispenser enables long-term time-lapse imaging using refractive-index matching water immersion objectives in any environment, including incubation.



## Automatic Correction Collar

Moves the objective correction collar to the optimum position for best resolution both remotely and by software control. Motorized collars allow users to adjust the correction collar without disturbing the specimen position, even in incubated enclosures or environmental chambers.

# Multiple Modalities

## LAPP Modular illumination system

The Ti2-E microscope supports up to 5 episcopic illumination sources, which can be used in tandem with AX/AX R confocal imaging: total internal reflection fluorescence (TIRF), point, raster or field stimulation devices, and fluorescence light sources can all be integrated onto the same microscope stand, and used in the same experiments.



## Total Internal Reflection Fluorescence (TIRF)

The incident angle of a laser and corresponding penetration depth of the evanescent field can be controlled via NIS-Elements software. When multiple TIRF modules are mounted, the penetration depth can be independently set for each wavelength.

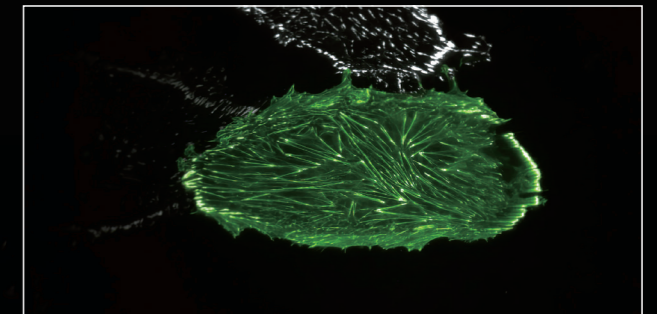

## Photostimulation: Point and Raster Scanner

The XY galvano scanning unit can stimulate the desired area of a sample using laser point scanning. It allows simultaneous photostimulation and confocal imaging.

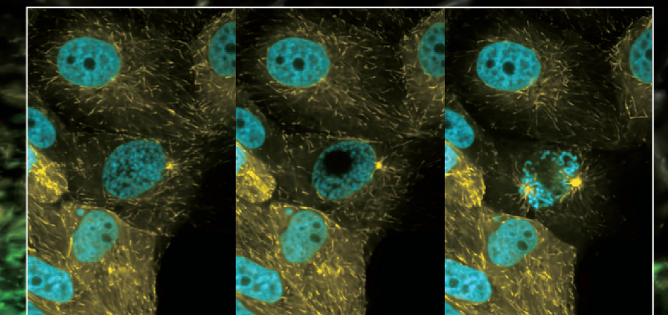

## Photostimulation: Digital Micromirror Device (DMD)

The DMD module enables photoactivation of user-specified patterns rather than photoactivation of a single spot. This allows stimulation of multiple points and tracking of their behavior. The DMD module can be used with either laser illumination or less phototoxic LED illumination.

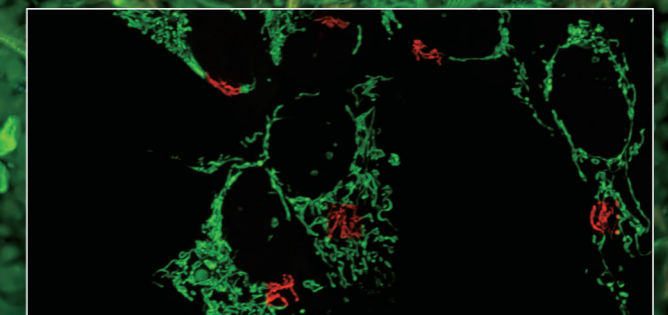

# System diagram

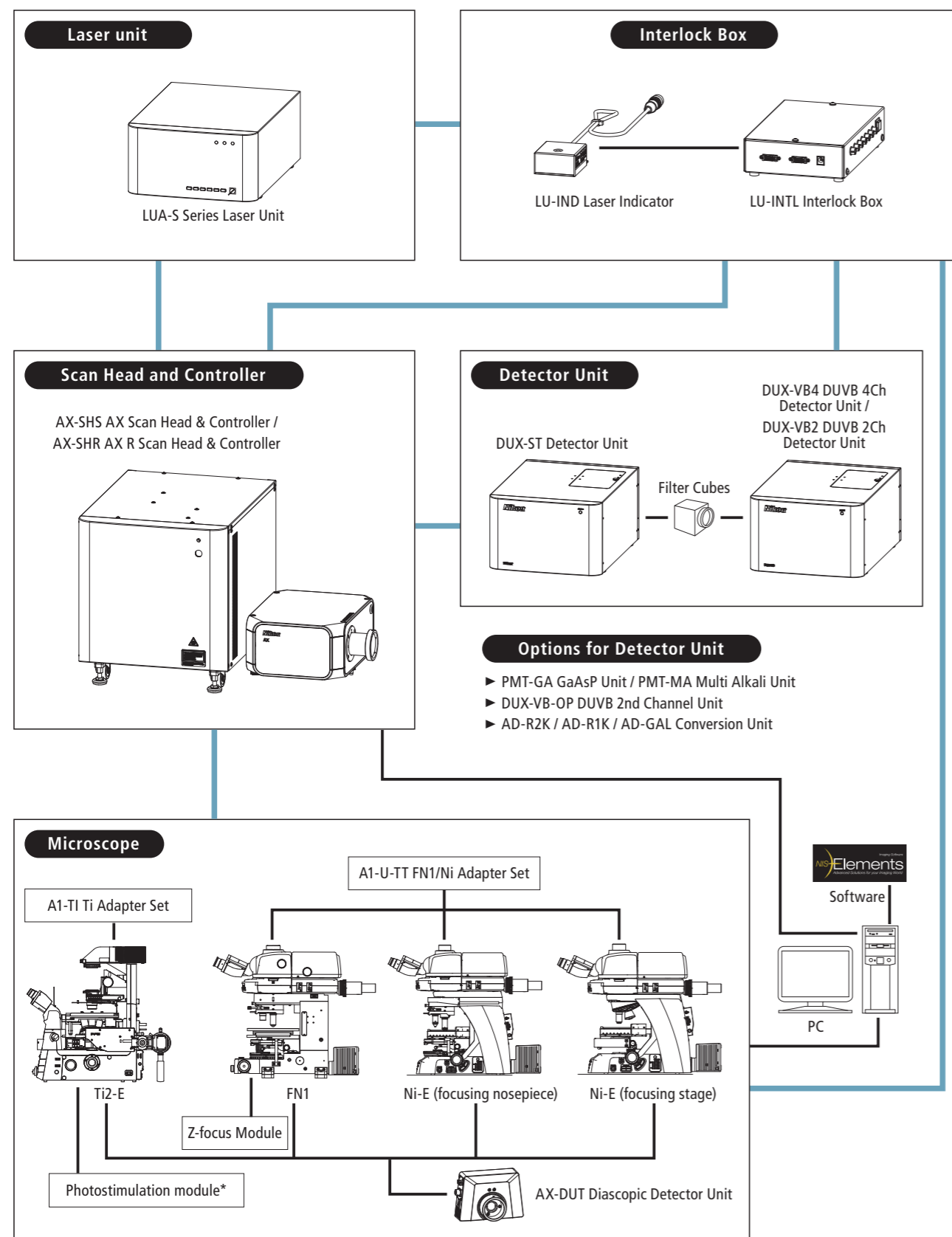

\* Adapter for Ti2-LAPP system, light source, hybrid dichroic mirror for photostimulation and imaging, and control board are all required.

# Specifications

Scan Head	AX Galvano Scanner	25 mm FOV galvano scanner Up to 8192 x 8192 pixels Up to 10 fps at 512 x 512 pixels Pixel dwell time up to 2 milliseconds Supports bidirectional imaging and linescan imaging
	AX R Galvano+Resonant Scanner 2K or 1K	25 mm FOV resonant scanner 25 mm FOV galvano scanner Up to 2048 x 2048 pixels for 2K (1024 x 1024 pixels for 1K) Up to 720 fps at 2048 x 16 pixels for 2K (720 fps at 1024 x 16 pixels for 1K) 30 fps at 2048 x 512 pixels for 2K (1024 x 512 pixels for 1K) Supports bidirectional imaging and linescan imaging
Scan Head Input/Output Port		2 laser input ports, FC fiber connection 2 signal output ports, FC fiber connection Excitation and Emission access ports
Dichroic Mirror		Up to 6 customizable mirrors
Pinhole		Continuously variable
FOV		Maximum 25 mm diameter (circle) inscribed by a rectangle
Laser		Up to 8 visible lasers Compatible range: 405-750 nm
Detector	DUX-VB	2 or 4 channels Freely tunable emission bands with $\pm 1$ nm accuracy and up to 66 discrete spectral channels Up to 12 bandpass filters Multi-alkali PMT or GaAsP PMT options
	DUX-ST	2 or 4 channels Up to 24 bandpass filters Multi-alkali PMT or GaAsP PMT options
Diascopic Detector		Compact PMT detector
Z step		Ti2-E: 0.01 $\mu$ m, 0.02 $\mu$ m (with encoder control), FN1 stepping motor: 0.05 $\mu$ m, Ni-E: 0.025 nm Piezo Z step: minimum 1.5 nm
Compatible Microscopes		Ti2-E inverted microscope with maximum FOV of 25 mm Ni-E and FN1 upright microscopes with maximum FOV of 25 mm
Option		Photostimulation (point raster or digital micromirror) Fluorescence lifetime imaging including fast FLIM Piezoelectric Z (or XYZ) Environmental chamber or enclosure Other modalities such as TIRF, N-STORM or N-SIM S
Software		Nikon NIS-Elements C Optional modules available Up to 16 bit images (65,536 gray levels with fine integration) with multiple file output options
Control Workstation		Microsoft Windows <sup>®</sup> 10 64bit Professional with GPU-accelerated graphics card
Recommended Installation Conditions		Temperature 23 $\pm$ 5 $^{\circ}$ C, Humidity 70% RH or less (no condensation)

# Layout

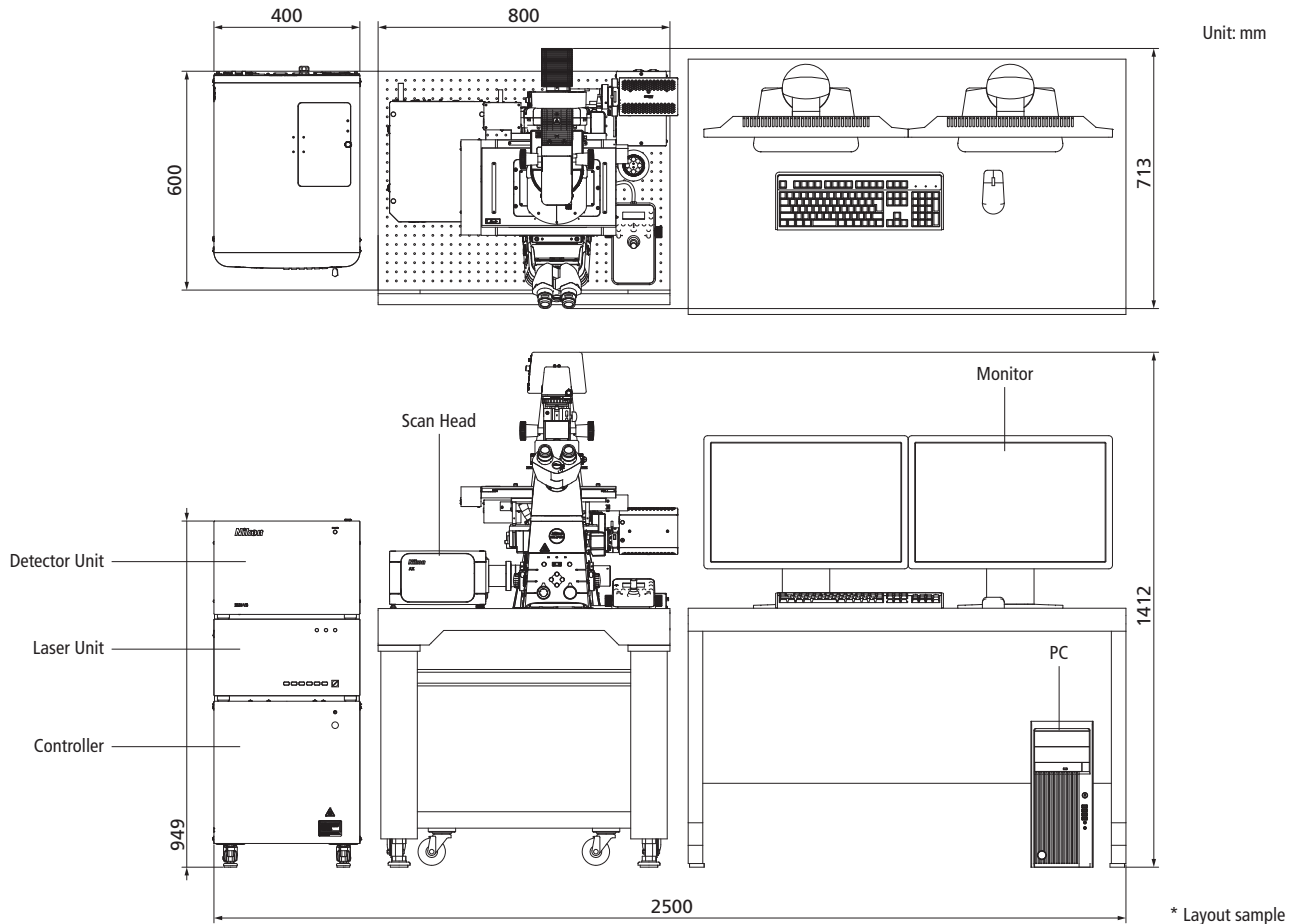

Specifications and equipment are subject to change without any notice or obligation on the part of the manufacturer. April 2021 ©2021 NIKON CORPORATION

**WARNING** TO ENSURE CORRECT USAGE, READ THE CORRESPONDING MANUALS CAREFULLY BEFORE USING YOUR EQUIPMENT.

Monitor images are simulated.  
Company names and product names appearing in this brochure are their registered trademarks or trademarks.  
N.B. Export of the products\* in this brochure is controlled under the Japanese Foreign Exchange and Foreign Trade Law. Appropriate export procedure shall be required in case of export from Japan.  
\*Products: Hardware and its technical information (including software)

**WARNING-LASER RADIATION  
AVOID EXPOSURE TO BEAM  
CLASS 3B LASER PRODUCT**  
Total Power 500mW MAX.  
CW 400-700nm  
IEC/EN60825-1 : 2007, 2014

Complies with FDA performance standards for laser products except for conformance with IEC60825-1 Ed.3., as described in Laser Notice No.56, dated May 8, 2019.

**DANGER-LASER RADIATION AVOID  
EYE OR SKIN EXPOSURE TO DIRECT  
OR SCATTERED RADIATION  
CLASS 4 LASER PRODUCT**  
Total Power 600mW MAX.  
CW 400-700nm  
IEC/EN60825-1 : 2007, 2014

Complies with FDA performance standards for laser products except for conformance with IEC60825-1 Ed.3., as described in Laser Notice No.56, dated May 8, 2019.



**NIKON CORPORATION**  
Shinagawa Intercity Tower C, 2-15-3, Konan, Minato-ku, Tokyo 108-6290, Japan  
phone: +81-3-6433-3705 fax: +81-3-6433-3785  
<https://www.healthcare.nikon.com/en/>

ISO 14001 Certified  
for NIKON CORPORATION

**Nikon Instruments Inc.**  
1300 Walt Whitman Road, Melville, N.Y. 11747-3064, U.S.A.  
phone: +1-631-547-8500; +1-800-52-NIKON (within the U.S.A. only)  
fax: +1-631-547-0299  
<https://www.microscope.healthcare.nikon.com/>

**Nikon Europe B.V. (headoffice)**  
Tripolis 100, Burgenweeshuispad 101, 1076 ER Amsterdam, Netherlands  
phone: +31-20-7099-000 fax: +31-20-7099-298  
[https://www.microscope.healthcare.nikon.com/en\\_EU/](https://www.microscope.healthcare.nikon.com/en_EU/)

**Nikon Instruments (Shanghai) Co., Ltd.**  
CHINA phone: +86-21-6841-2050 fax: +86-21-6841-2060  
(Beijing branch) phone: +86-10-5831-2028 fax: +86-10-5831-2026  
(Guangzhou branch) phone: +86-2-3882-0551 fax: +86-2-3882-0580  
[https://www.microscope.healthcare.nikon.com/zh\\_CN/](https://www.microscope.healthcare.nikon.com/zh_CN/)

**Nikon Canada Inc.**  
CANADA phone: +1-905-625-9910 fax: +1-905-602-9953  
**Nikon France, Succursale de Nikon Europe B.V.**  
FRANCE phone: +33-1-4516-4516 fax: +33-1-4516-4505

**Nikon Deutschland, Zweigniederlassung der Nikon Europe B.V.**  
GERMANY phone: +49-211-9414-888 fax: +49-211-9414-322

**Nikon Italy, Branch of Nikon Europe B.V.**  
ITALY phone: +39-055-300-9601 fax: +39-055-300-993

**Nikon Europe B.V., Amsterdam, Zweigniederlassung Schweiz (Egg/ZH)**

SWITZERLAND phone: +41-43-277-2867 fax: +41-43-277-2861

**Nikon UK, Branch of Nikon Europe B.V.**  
UNITED KINGDOM phone: +44-208-247-1717 fax: +44-208-541-4584

**Nikon Österreich, Zweigniederlassung der Nikon Europe B.V.**  
AUSTRIA phone: +43-1-972-6111 fax: +43-1-972-6111-40

**Nikon Singapore Pte Ltd**  
SINGAPORE phone: +65-6559-3651 fax: +65-6559-3668

**Nikon Instruments Korea Co., Ltd.**  
KOREA phone: +82-2-6288-1900 fax: +82-2-555-4415